

# Installation Guidelines

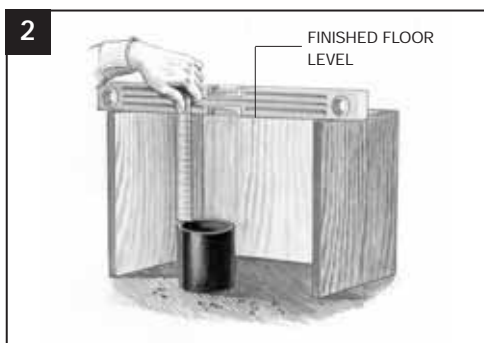

1. Where applicable, screw spigot adaptor into the body outlet using a suitable sealant to ensure the joint is watertight.



2. Measure the distance between the top of the connecting pipework and finished floor level.

3. Check that this distance will enable the complete gully (with extensions, if applicable) to be installed with the top face of the grating or cover flush and level with the finished floor.

**Note:** Where a damp-proof membrane is used, the body must be installed with the top of the flange at or below membrane level.

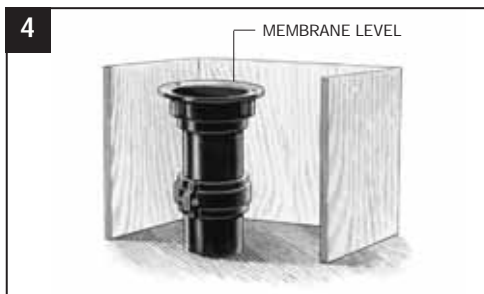

4. Connect body (with spigot adaptor if applicable) to pipework.  
5. Infill as required.



6. Where applicable, dress the membrane over the flange and into the sump of the body, ensuring that the membrane does not restrict the outlet; bolt the membrane clamping collar to the body – certain collars are reversible to increase height adjustability.

**Note 1:** If a G series is being used without a membrane, ensure that membrane clamping collar securing holes in top face of body are sealed.

**Note 2:** In some cases the membrane clamping collar serves to connect the grating or cover to the body, so it must be fitted even where a membrane is not used.

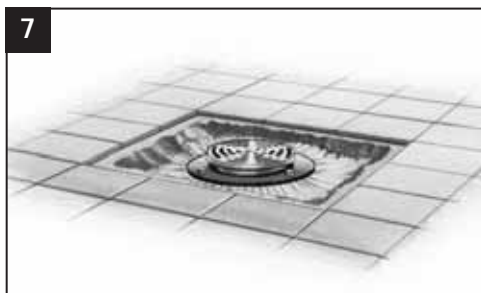

7. Fit grating, cover, or funnel with extensions, frame or collar as applicable; set top face flush and level with the finished floor using height adjustability features. Use a suitable sealant on all threaded joints to ensure a watertight assembly.

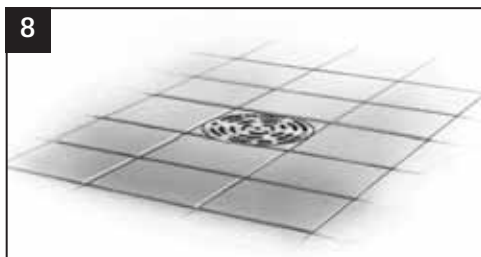

8. Infill or lay floor screed and apply final floor finish (e.g. tiles, marble, paviors, terrazzo) around the grating or cover.

**Note:** Installation of gratings and covers for use with sheet floor covering, such as vinyl, is illustrated on page 35F.

# Installation Guidelines

## Gratings and Access Covers for use with Sheet Floor Covering

Worldwide demand for higher standards of hygiene and safety in buildings is reflected in the increasing use of modern slip-resistant flooring. In keeping with its position at the forefront in the design and manufacture of gullies, Wade has developed a range of superbly finished products specifically for use with flexible sheet floor covering such as vinyl, and with certain trowel applied resins. Where a clamping collar is fitted a watertight seal is obtained, yet gratings and covers are removable for access to pipework without disturbing the flooring material.

**G202** Cast iron body with K2302 nickel bronze grating

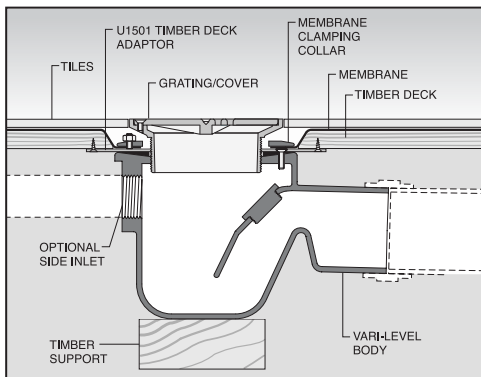

Typical installation in a wooden floor



Watertight Drainage in a vinyl covered timber floor

N213 nickel bronze grating, with cast iron backnut, connected directly to 40mm plastic pipework.

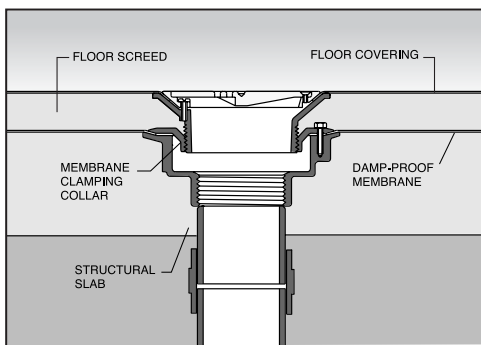

Typical installation with damp-proof membrane

To achieve a watertight joint, installation must be in accordance with instructions which accompany the gratings/covers.

